

# Vanvex 185 - 285

## Description

Vanvex domestic water heat pump is a complete unit consisting of a 185/285-litre hot-water cylinder, extract fan, heat pump and Optima 180 control. The S-models are with an intentional heating element ready for connection to solar panels.

## Suitability

Vanvex domestic water heat pump can utilise the energy of both indoor and outdoor air for heating domestic water and is capable of covering a family's hot water requirements all year round.

## Capacity

The heat pump can produce approx. 380 l of hot water a day at a temperature of 55°C. Capacity is dependent on the outside temperature, the supply temperature of the cold water and the draining off pattern. If the cylinder is emptied of hot water, it is possible to connect a 1 kW electric heating element, which will help quickly heating up the water. When the desired temperature has been reached, the electric heating element will switch off. Energy consumption is normally 30% of consumption using an electric water heater.

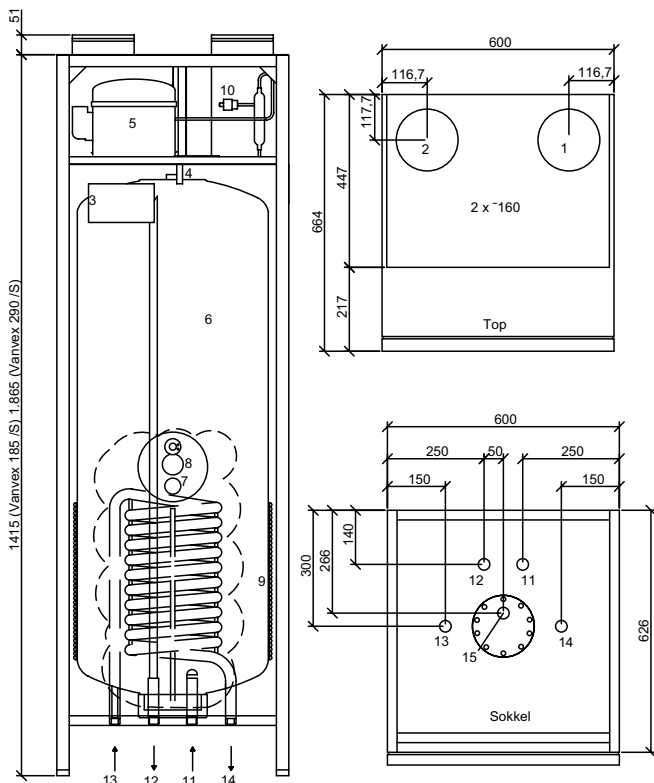

- |  |   |
|--|---|
| 1: Fresh air                             | 9: Condensing coil  |
| 2: Exhaust                               | 10: High-pressure gov. with manual reset  |
| 3: Electrical connection/automatics fuse | 11: Cold-water inlet 3/4" RG pipe thread  |
| 4: Condensation drain                    | 12: Hot-water outlet 3/4" RG pipe thread  |
| 5: Compressor                            | 13: Connection for the internal heating coil. 3/4" RG pipe thread (only the S-type) |
| 6: 185/285-litre cylinder                | 14: Connection for the internal heating coil. 3/4" RG pipe thread (only the S-type) |
| 7: 3/4" anode                            | 15: Hot-water circulation 3/4" RG pipe thread                                       |
| 8: 1 kW electrical heating element       |   |

## Construction

### Main dimensions:

(h x l x d) ex. connecting pieces  
 Vanvex 185 /S: 1415 x 600 x 664 mm  
 Vanvex 285 /S: 1865 x 600 x 664 mm

### Cabinet:

Fully closed hot galvanised plate with 30 mm Isolation. The cylinder is fully insulated with polyurethane foam. Plastic-coated white RAL 9010.

### Duct connection:

Ø160 mm with rubber ring seal

### Protection of the cylinder:

Enamel and magnesium anode inside

### Condenser:

D-pipe condenser wrapped around the outside of the cylinder.

### Protection of the internal heating coil (only the S-type):

Enamel outside

### Front:

Front with bolts in the top

### Condensation tub:

Stainless steel

### Condensation drain:

Synthetic tube Ø15 mm (inside)

### Weight without /with water:

Vanvex 185:	190/375 kg
Vanvex 185S:	195/380 kg
Vanvex 285:	205/495 kg
Vanvex 285S:	210/500 kg

# Vanvex 185 - 285



## Technical data

### Electrical connections

1 x 230 V + N + PE, 10 A, 50 Hz

### Fan with directly connected motor

R2E 190

### Condenser

2.0 µF

### Isolation class

B

### Class

IP 44

### Motor data:

2500 Rpm

58 W

0.26 A

### The air volume

50 % of max. speed at 25 Pa extern of presure loss - 135m<sup>3</sup>/h

100 % of max. speed at 100 Pa extern of presure loss - 280m<sup>3</sup>/h

### Compressor

NE 6210 Z

### Effect collection (max)

585 W

### Power consumption (max)

3.14 A

### Average performance

1365 W

### Average effect consumption

425 W

### Cooling medier

R134a

### Filling

1100 gr.

### Electrical heating coil

Effect consumption 1.0 kW

Power consumption 4.3 A

### Cylinder capacity

185/ 285 Liter

### Standby loss

50 W/70 W

### Max. operating pressure

10 Bar

### Surface area of heating coil

0.8 m<sup>2</sup>

## Sound data

Measuring point	1 m in front of the unit		Extract duct	
	Airflow	50%	100%	50%
	Lo dB		Lwu dB	
63 HZ	41	43	74	83
125 Hz	42	44	76	84
250 Hz	36	40	63	80
500 Hz	34	38	60	73
1000 Hz	26	28	47	64
2000 Hz	23	25	44	61
4000 Hz	-	21	39	56
8000 Hz	-	-	32	38
Average	Lo dB(A)		Lwu dB(A)	
	35	39	66	79

## Automatics

The equipment is delivered with Optima 180 control panel. The control panel is on the front cover.



### Operating menu

The value of each menu point can be changed by pressing on the bottom below.



#### P1: Step

Here is it possible to shift between: standby, automatics operation, constant operation and timer-controlled constant operation (step 0, step 1, step 2, step 3)



#### P2: Electrical heating element ON

The heat pump is delivered with an extra electrical heating element for heating the domestic hot water. Here it is possible to give a signal to the electrical heating element when needed



#### P3: Operating thermostat for heat pump

It is possible to adjust at the domestic hot water temperature between 0-55°C



#### P4: Stop defrost

Stops the defrost when the cooling coil have a temperature of 8°C, which is the standard setting. The temperature can be adjusted between 0-10°C

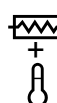

#### P5: Electrical heating coil

It is possible to adjust the domestic hot water temperature between 0-65 °C



#### The display

On the display it is possible to show different temperatures by a pressing the arrow key down or the arrow key up until you reach the operation needed

