

GE Premium 3

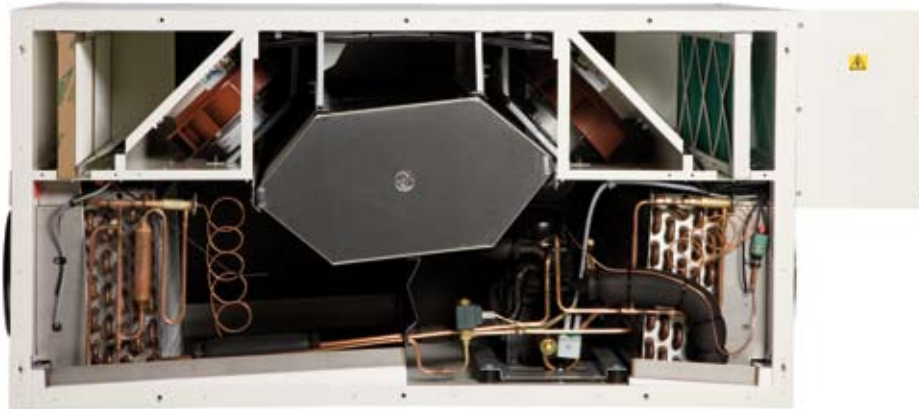

Description

GE Premium 3 is a ventilation unit consisting of a counter current heat exchanger, a heat pump, supply and extract air fans, F7 supply air filter, G4 extract air filter, complete Optima 300 automatics and control panel.

GE Premium 3 has also got a cooling function.

GE Premium 3 can be delivered with the following options:

- Water and electrical heating element for Ø200 mm duct mounting
- Water frost sensor
- Fresh air and extract air damper with motor for Ø200 mm duct
- Thermostat or motor valve

Suitability

GE Premium 3 is suitable in ventilation systems where balanced ventilation, heat recovery and warm/cool supply air is needed.

At first the heat will be recovered in the counter current heat exchanger and then further heat will be supplied to the supply air by the heat pump. During the summer the heat pump can switch to a cooling mode which means that the heat pump will supply cooling to the supply air.

GE Premium 3 is normally used in homes with an area up to 778 square metres (at an average room height at 2.4 m and an air exchange rate of 0,3 1/h).

Air exchange/h	Max. capacity m³/h	Living area m²*
0.3	560	778
0.4	560	584
0.5	560	467

* The power consumption is not included when calculating the living area

Dimensions

GE Premium 3
Dimension in mm

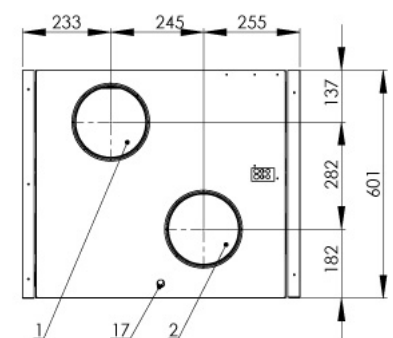
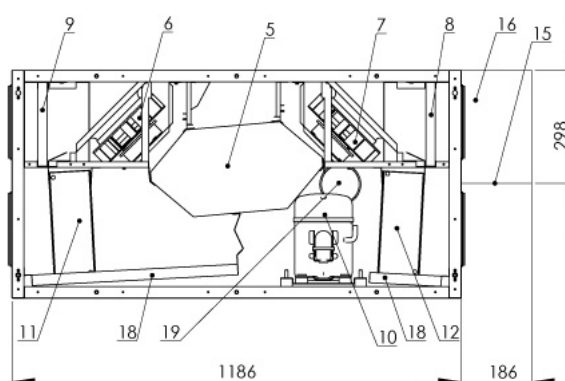
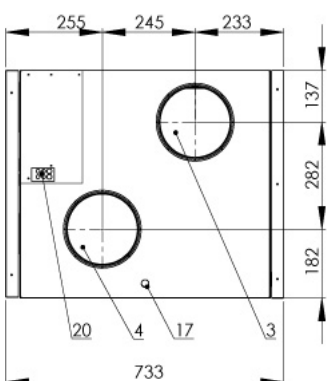

- | | | | | |
|-------------------------------|------------------------|-------------------------|----------------------------------|--------------------------------|
| 1: Fresh air Ø200 | 7: Extract air fan | 13: High-pressure gov. | 19: Supply boss at the back Ø100 | 25: Sensor for fresh air |
| 2: Exhaust air Ø200 | 8: Filter, extract air | 14: Process valve | 20: Switch | 26: Sensor for supply air |
| 3: Extract air Ø200 | 9: Filter, supply air | 15: Cable entry | 21: Magnetic valve defrosting | 27: Sensor before cooling coil |
| 4: Supply air Ø200 | 10: Compressor | 16: Electrical box | 22: Thermostat condenser | 28: Sensor for cooling coil |
| 5: Counter current heat exch. | 11: Evaporator | 17: Condensat.conn. Ø15 | 23: Thermostat evaporator | 29: Sensor for exhaust air |
| 6: Supply air fan | 12: Condensator | 18: Condensation tubs | 24: Sensor for extract air | 30: Four-way valve |

GE Premium 3



Technical data

Electrical connections:

Without electrical heating and preheating coil

1 x 230V + N + PE + 10 A, 50 Hz

With electrical heating and preheating coil

Max 1.2 + 1.0 kW

1 x 230V + N + PE + 16 A, 50 Hz

Fans:

R3G 220 AE 50

Motor:

EC motor with integrated electronics

Isolation class:

B

Class (fans):

IP 44

Motor capacity (Max. per motor):

3510 Rpm

Current input (Max. per motor):

157 W

Power consumption (Max. per motor):

1,10 A

Speed regulation:

Individually the fans can be set to 3 different speeds

The working area of the heat pump:

-15°/+35°C

Compressor:

NE 6220 GK

Min. air volume:

230 m³/h

Effect consumption (max.):

1104 W

Cooling performance:

1580 W

Power consumption (max.):

5,1 A

Average performance:

2690 W

Average effect consumption:

910 W

Cooling medier:

R407c

Filling:

1300 gram

Automatics

GE Premium 3 is delivered with Optima 300 automatics with a factory settings so that the unit can be started, without setting up the menu. The factory settings are standard settings, that can be changed to the specific needs and demands of your living area.

Control panel



Speed (1)

Use this function to set the fan speed to levels 0-1-2-3-4.



Extended operation (2)

Use this function to set the timer to forced operation from 0 to 9 hours.



Cooling (3)

Use this function to turn on or off the supplementary after-heat.



Main menu (4)

Use this function to enter the main menu and access the sub-items date, calendar, user menu, display, information menu and service menu.



Filter (5)

Use this function to reset the filter alarm.



Information (6)

Use this function to get a good overview of the device's current operating condition.



Temperature (7)

Use this function to set the room temperature.

Sound data

Measuring point	1 m in front of the unit			Extract air duct			Supply air duct			
	Airflow	1	2	3	1	2	3	1	2	3
		Lo dB			Lwu dB			Lwi dB		
63 Hz	55	55	51	85	94	99	92	95	97	
125 Hz	45	49	55	76	89	96	76	89	95	
250 Hz	51	50	53	70	81	86	71	85	92	
500 Hz	-	37	42	59	79	88	61	83	90	
1000 Hz	-	32	38	57	73	81	57	72	83	
2000 Hz	-	-	36	52	64	74	57	68	77	
4000 Hz	-	-	32	46	60	66	49	52	63	
8000 Hz	-	-	-	39	58	63	43	43	51	
		Lo dB(A)			Lwu dB(A)			Lwi dB(A)		
Average	41	43	48	66	80	88	69	83	90	

1: Measured at 40% of max. speed with compressor on

2: Measured at 70% of max. speed with compressor on

3: Measured at 100% of max. speed with compressor on



Capacity

The capacity lines are based on an average of the supply and extract air volume in a unit with filters.

Max. Capacity:

At 100 Pa the max. capacity is: 560 m³/h.

With an average room height of 2.4 m, the living area is calculated as follows:

$$\text{Living area (m}^2\text{)} \times \text{Room height (m)} \times \text{Air exchange/h} = \text{Max. capacity}$$

Living area (m²) =

$$\frac{\text{Max. capacity (m}^3\text{/h)}}{\text{Room height (m)} \times \text{Air exchange (h}^{-1}\text{)}}$$

Example:

$$\text{Living area (m}^2\text{)} = \frac{560 \text{ m}^3\text{/h}}{2.4 \times 0.5\text{h}^{-1}} = 466,67 \text{ m}^2$$

* The power consumption is not included when calculating the living area

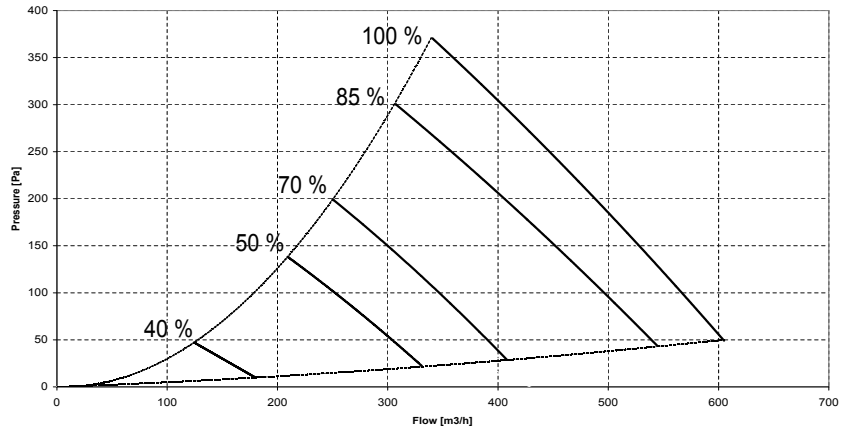

Total power consumption

For both fans and control.

- 1 = 100%
- 2 = 85%
- 3 = 70%
- 4 = 50%
- 5 = 40%

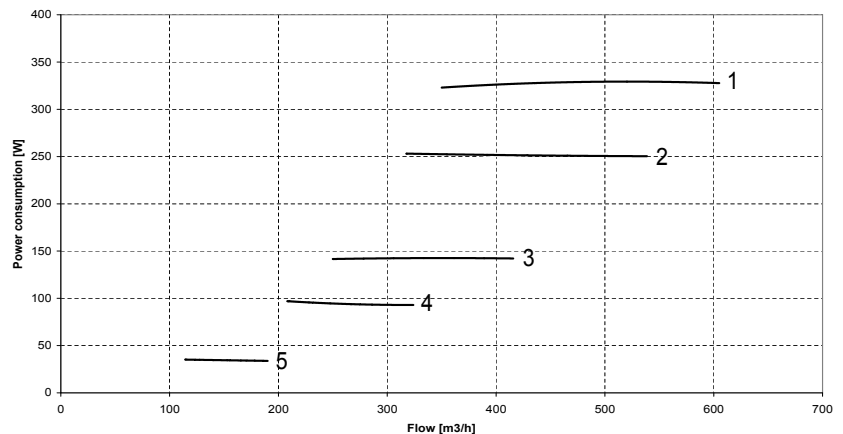

Heat recovery

Heat recovery flow $m_{in} = m_{out}$

Icing of the heat exchanger at low outdoor temperatures has been left out of account.

- 1 = Temp.: -12 °C
RF.: 50%
- 2 = Temp.: 4 °C
RF.: 50%

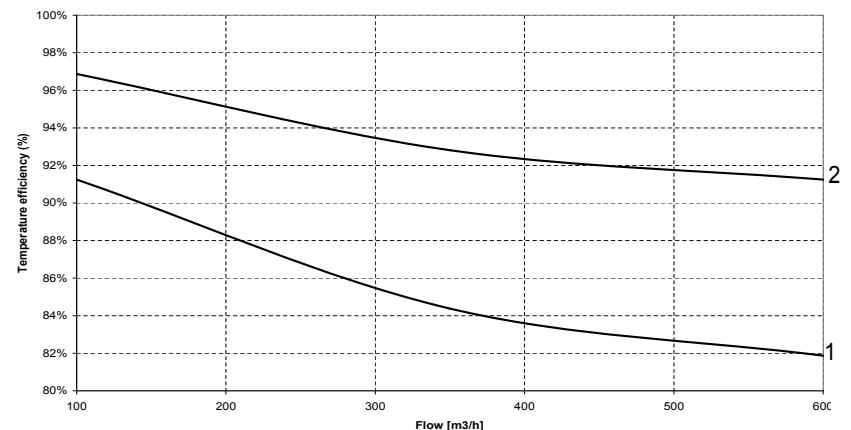

GE Premium 3

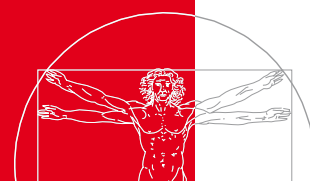

Construction

Size:

(h x l x d) ex. connecting pieces and electric box
600 x 1186 x 735 mm

Cabinet:

Fully closed hot galvanised plate with 30 mm Insolation.
Plastic-coated white RAL 9010.

Duct connection:

Ø200 mm with rubber ring seal

Front:

Front with quick locks for filter service

Heat exchanger:

See water resistant aluminium

Condensation tub:

Stainless steel

Condensation connection:

Stainless steel Ø15 mm

Filters:

Fresh air: F7 filter

Exhaust air: G4 filter

Weight:

143 kg

Flow diagram

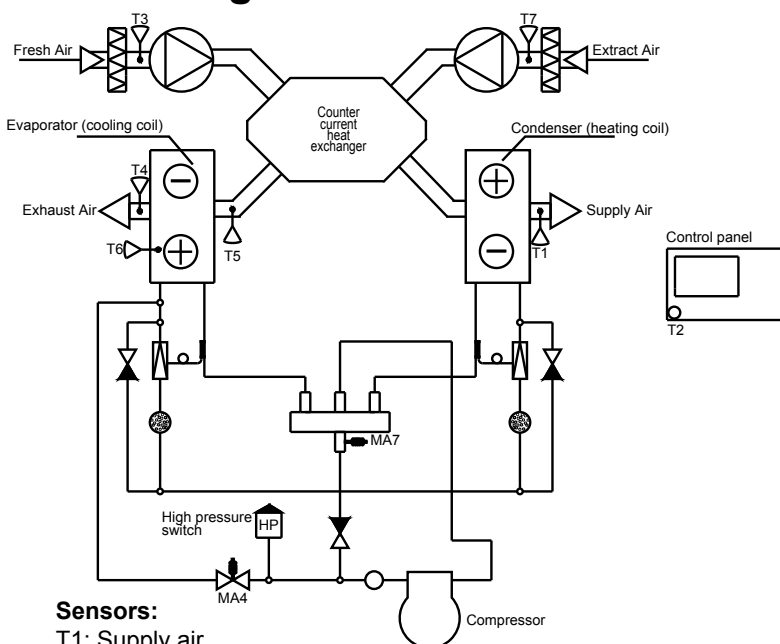

Sensors:

T1: Supply air

T2: Room

T3: Fresh air

T4: Extract air

T5: Before the cooling coil

T6: Cooling coil

T7: Exhaust air

T8: Water freezing (for the water-afterheating surface)

Magnetic valve:

MA4: Defrosting

MA7: Heat/cooling

Capacity

GE Premium 3' capacity varies with air quantity and outdoor air temperature

Airflow 395 m³/h.

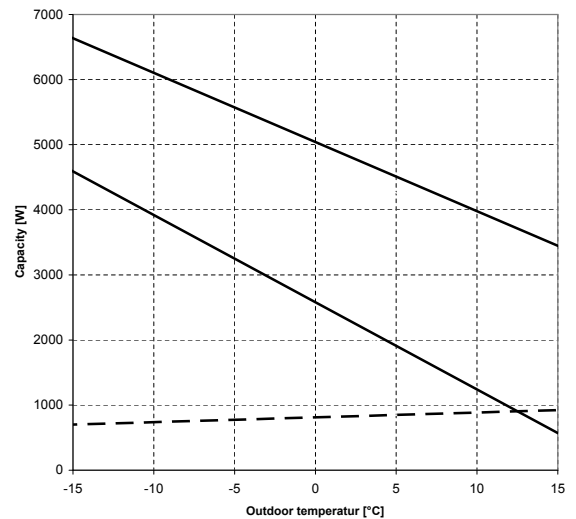

Airflow. 568 m³/h.

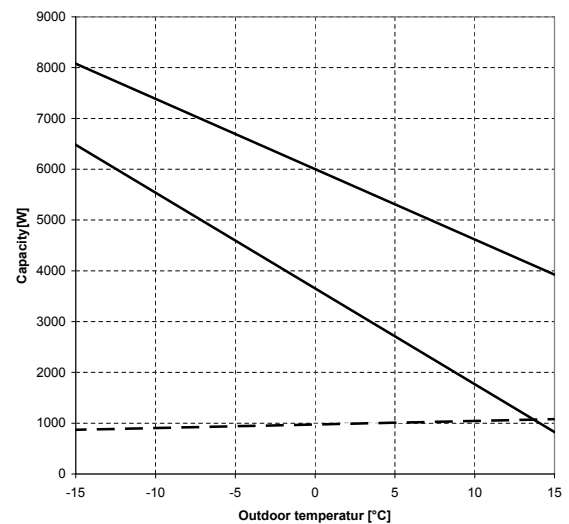

- 1) Energy consumption for heating supply air to room temperature 20°C.
- 2) Total capacity of the unit
- 3) Power input with compressor running

The area between 1 and 2 is GE Premium 3's contribution for roomheating

Cooling capacity:

With an outside temperature of 26°C, relative humidity of 45% and full speed, the cooling power output is 2385 W.